

# RENAULT SPORT CLIO 197, MEGANE dCi 175, MEGANE 225



PASSION, PERFORMANCE, PANACHE  
IT TAKES A PERFORMANCE CAR  
ENTHUSIAST TO APPRECIATE THE  
BEAUTY OF RENAULT SPORT.  
SHARING THAT SAME PASSION  
FOR PERFORMANCE, THE  
RENAULT SPORT TEAM EXCELS  
AT TAKING ALREADY GREAT  
CARS AND TURNING THEM INTO  
THE ULTIMATE DRIVING EXPERIENCE.





The very fact that you're reading this brochure means you see a car as more than just a way of getting from A to B. It has to have style, it has to have performance and it has to have street cred. The team at Renault Sport give you all that in bucket loads.

As the specialist unit that creates Renault's range of high-performance cars, Renault Sport has taken two of the most exciting hot hatches on the market and introduced some of the performance-enhancing DNA that Renault developed during the last century of motor sport. From the classic city-to-city races at the dawn of the automobile, through Le Mans and the Monte Carlo Rally to today's Formula 1, Renault has always been a winner.

Unsurprisingly, this impeccable racing heritage has resulted in the creation of an incomparable Renault Sport range for the 21st Century. Today's inspiring series of high-performance vehicles includes the sublime Mégane Renault Sport 225 and Renault F1 Team R26.

Stretching performance boundaries ever further, Renault Sport has now introduced the Clio 197 and the Mégane dCi 175. The result is a choice of high performance vehicles that take an uncompromising approach to performance and comfort, for the ultimate Renault driving experience.



## **CLIO RENAULT SPORT 197**

SOME HATCHES LOOK GOOD, SOME ARE FAST – THIS IS BOTH



The Clio Renault Sport 197 has redefined what constitutes a hot hatch with sensational performance from its powerful 2.0L engine, advanced chassis dynamics and a F1-developed air diffuser keeping it firmly glued to the road.

From supportive sports seats to sport-biased ESP which you can disconnect if you're on the track, Renault Sport has created the ultimate driving environment.

The engine has been extensively revised from the previous Clio Renault Sport 182 with new inlet tracts, valve seat aerodynamics, camshaft, crank shaft and pistons. Continuously variable valve timing results in 145kw of power at 7250rpm and 215Nm of torque at 5550rpm. And with the close ratio 6 speed gearbox, changing gears has never been so sweet or rewarding.



# COLOURS



NNF

TORO RED (SOLID)

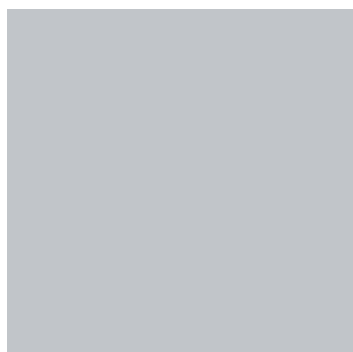

F60

SILVER (METALLIC)

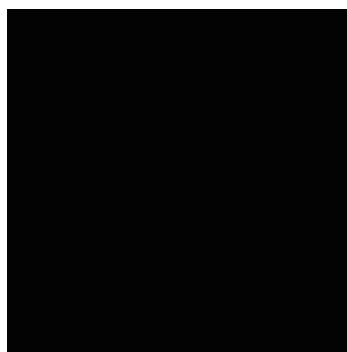

GNA

DEEP BLACK (METALLIC)



RNC

MONAKO BLUE (METALLIC)

It should be noted that printing limitations do not permit the subtle paintwork shades on these pages to be shown with absolute accuracy. Only personal inspection of the Clio at your Renault Dealer will reveal it in its true colours. From time to time changes are made to the colour range. Please check availability with your Renault Dealer.



Aluminium drilled pedals



F1 inspired rear diffuser



17" Renault Sport alloy wheel

## CLIO 197 TECHNICAL SPECIFICATIONS

2.0 Petrol MT 3-door	
<b>ENGINE</b>	
Type	Euro 4
Capacity (cc)	1,998
Bore x stroke (mm)	82.7 x 93
Number of cylinders/valves	4 in-line/16
Compression ratio	11.5:1
Max. power kW	145
Max. power (rpm)	7,250
Max. torque Nm	215
Max. torque (rpm)	5,550
Injection	Multipoint
Fuel	Premium unleaded (98 RON rec.)
<b>TRANSMISSION</b>	
Type	6-speed Manual
Speeds at 1000rpm in	
1st gear	8.33
2nd gear	13.62
3rd gear	17.88
4th gear	21.99
5th gear	27.36
6th gear	32.77
<b>STEERING</b>	
Type	Variable Electric Power Assist
Turning circle between kerbs/walls (m)	11/11.40
Turns lock-to-lock	2.83
<b>SUSPENSION</b>	
Front suspension	Double-axis strut system
Rear suspension	Torsion beam with programmed deflection – coil springs
Front/rear anti-roll bar - dia (mm)	20/30 integrated
<b>WHEELS AND TYRES</b>	
Wheels (inches)	7.5 J 17
Tyres	215/45 R 17
<b>BRAKING</b>	
Front Braking System	Brembo® 4 piston calipers – Ventilated discs (312mm)
Rear Braking System	Solid discs (300mm)

2.0 Petrol MT 3-door	
<b>PERFORMANCE</b>	
Max speed (kph)	223
0 to 100km/h	6.9
<b>FUEL CONSUMPTION<sup>^</sup></b>	
City (L/100km)	11.6
Highway (L/100km)	6.5
Combined cycle (L/100km)	8.4
CO2 Emissions (g/km) Euro4	199
<b>CAPACITY</b>	
Fuel tank (litres)	55
<b>WEIGHTS</b>	
Kerb weight (kg)	1,221
Gross vehicle weight (kg)	TBC
<b>DIMENSIONS</b>	

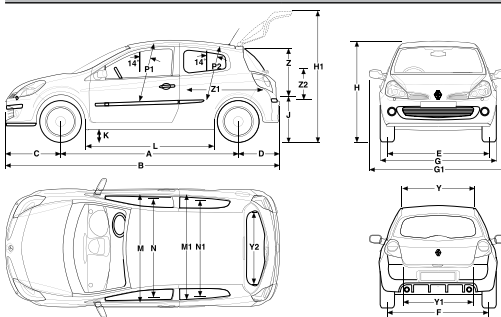

A	2,585mm	H1	1,994mm	P2	861mm
B	3,991mm	J	678mm	Y	848mm
C	800mm	K	120mm	Y1	894mm
D	606mm	L	1,677mm	Y2	1,028mm
E	1,520mm	M	1,402mm	Z	652mm
F	1,520mm	M1	1,412mm	Z1	1,306mm
G	1,768mm	N	1,382mm	Z2	541mm
G1	2,025mm	N1	1,362mm		
H	1,484mm	P1	907mm		

<b>VOLUME</b>	
Under rear parcel shelf (litres)	288
Rear seats folded to the roof (litres)	1,038

<sup>^</sup>Vehicle tested in accordance with ADR 81/02. Actual fuel consumption and CO2 emissions depend on factors such as traffic conditions, vehicle condition and how you drive.

## CLIO 197 PRODUCT FEATURES

<b>SAFETY AND SECURITY</b>
<b>Active and Passive Safety Features</b>
ABS with EBD (Electronic Brake Distribution)
Sports-tuned ESP (Electronic Stability Program) with disconnection function
Front, lateral and curtain airbags
Anti-submarining airbags
Height adjustable three point front seatbelts with integrated pretensioners and load limiters
3 point rear seatbelts (three) with pretensioners on the outer rear seats
Automatic headlights and wipers
Height adjustable headlamps
Double optic headlamps, front fog lamps and “see me home” headlights
<b>Security Features</b>
Engine immobiliser
Remote central locking and Renault Anti Intruder Device (R.A.I.D)
<b>INTERIOR FEATURES</b>
Height adjustable Renault Sport leather steering wheel with red centreband and leather gear lever
New generation height adjustable front headrests
Three height adjustable rear headrests with two pre-set positions
Black centre console with ‘soft touch’ dashboard and satin chrome detail
Multi function trip computer and multifunctional digital display
4x15w AM/FM single CD stereo with fingertip remote control
Climate control air conditioning
Tinted windows
Electric front windows with anti-pinch function and one touch control
Renault Sport seats with Renault Sport embroidery
Height and lumbar adjustable driver’s seat
60:40 Split folding rear seat
Drilled aluminium pedals
Bootspace and glovebox light
Interior courtesy light with time delay
Driver and passenger map reading lights
<b>EXTERIOR FEATURES</b>
Renault Sport extended front wings with integrated side air extractors, extended rear wings and sills
Rear air diffuser with twin chrome exhaust outlets
Satin chrome exterior and interior door handles
17" Renault Sport alloy wheels
<b>OPTIONS</b>
Metallic paint
Panoramic sunroof
4x40W Cabasse radio with dashmounted 6 CD changer, fingertip remote controls and 6 speakers
Xenon headlights and headlight wash
<b>WARRANTY</b>
3 Year/100,000km with 24 Hour Roadside Assistance



Overseas model shown

# MEGANE RENAULT SPORT dCi 175

## TALK THE TORQUE

There's no question, owning a Renault Sport vehicle assures you of an unbeatable driving experience. However for some, that's not enough. As well as awesome motoring power, they want excellent fuel economy and reduced emissions.

Enter the Mégane Renault Sport dCi 175. The first ever diesel model in the Renault Sport range, it boasts environmentally sound emissions of 165g/km\*, from an engine that delivers a super-efficient combined fuel consumption of 6.3L/100km\*. And all this is supported by the most powerful 2.0L diesel engine on the Australian market! (Source: ROADTODATA 07/2008)

In addition, owning a high-performance car doesn't mean that comfort is taken out of the equation. The Mégane dCi 175 has leather seats, xenon lamps, cruise control and 6-CD changer AM/FM radio as standard.

Mégane dCi 175 – Increased emotions = reduced emissions.



\*Vehicle tested in accordance with ADR 81/02 (litres/100km combined cycle).



Overseas model shown



Overseas model shown (seats shown not available in Australia).

# MEGANE RENAULT SPORT 225 5-DOOR

IF YOU'RE SERIOUS ABOUT HAVING FUN

With a 2.0L turbocharged power unit putting out a whopping 165kw, you might think the Mégane Renault Sport 225, would be a stripped-out competition special with very little in the way of creature comforts. But you'd be wrong.

This is a car for the driver who wants mind-blowing performance, but not at the expense of their comfort. The contoured seats gently cradle your body during fast cornering, while providing support and comfort for long distance motorway cruising.

The aggressive, yet sleek bodywork houses a finely tuned chassis, engineered to give crisp feedback to the driver. The Brembo brakes inspire confidence every time you need to wash off speed quickly.

For extra street cred the interior is trimmed in carbon leather. Nobody said that a performance car interior couldn't be radically stylish.

The Mégane 225 – Enjoy your drive.



Overseas model shown

# MEGANE RENAULT SPORT

## IF YOU'RE SERIOUS ABOUT HAVING FUN.

### TECHNICAL SPECIFICATIONS

	RS 225 5-door 2.0 Petrol MT	RS 175 5-door 2.0 dCi MT
<b>ENGINE</b>		
Capacity (cc)	1,998	1995
Bore x stroke (mm)	82.7 x 93	84 x 90
Number of cylinders/valves	4/16	4/16
Compression ratio	9.0:1	15.5:1
Max. power kW	165	127
Max. power (rpm)	5,500	3,750
Max. torque Nm	300	360
Max. torque (rpm)	3,000	2,000
Injection	Multipoint	Commonrail direct injection
Induction	Intercooled turbo	
Fuel	Premium unleaded (98 RON rec.)	Diesel
<b>TRANSMISSION</b>		
Type	6-speed Manual	6-speed Manual
Speeds at 1,000rpm in		
1st gear	8.91	8.61
2nd gear	14.45	15.99
3rd gear	20.17	24.27
4th gear	26.61	32.91
5th gear	34.7	41.37
6th gear	41.71	49.96
<b>STEERING</b>		
Type	Power steering	Power Steering
Turning circle between kerbs/walls (m)	10.35/11.25	10.35/11.25
<b>SUSPENSION</b>		
Front suspension	MacPherson type with L-shaped lower arm, independent steering axis and anti-sway bar	
Rear suspension	H-style rear axle and anti-sway bar	
Cup Chassis	S	
<b>WHEELS AND TYRES</b>		
Wheels (inches)	8 x 18"	8 x 18"
Tyres	235/40R18	225/40R18
<b>BRAKING</b>		
Front Braking System	Brembo® 4 piston calipers – Ventilated discs (312mm)	
Rear Braking System	Solid and drilled discs (300mm)	Solid discs (300mm)
<b>PERFORMANCE</b>		
Max speed (kph)	236	220

	RS 225 5-door 2.0 Petrol MT	RS 175 5-door 2.0 dCi MT
0 to 100km/h	6.5	8.5
<b>FUEL CONSUMPTION<sup>^</sup></b>		
Combined cycle (L/100km)	8.4	6.3
CO2 Emissions (g/km)	199	165
<b>CAPACITY</b>		
Fuel tank (litres)	60	60
<b>WEIGHTS</b>		
Kerb weight (kg)	1,361	1,380
Gross vehicle weight (kg)	1,820	1,895
<b>DIMENSIONS</b>		



A	2,617mm	H1	1,812mm	Q	944mm
B	4,228mm	J	708mm	Y	850mm
C	857mm	K	120mm	Y1	880mm
D	754mm	L	1,700mm	Y2	1,125mm
E	1,517mm	M	1,474mm	Z	815mm
F	1,521mm	M1	1,456mm	Z1	1,620mm
G	1,777mm	N	1,409mm	Z2	510mm
G	2,026mm	N1	1,380mm		
H	1,437mm	P	987mm		

S Standard.

<sup>^</sup>Vehicle tested in accordance with ADR 81/02 or ADR 81/01.

Actual fuel consumption and CO2 emissions depend on factors such as traffic conditions, vehicle condition and how you drive.

## PRODUCT FEATURES

	RS 225 5-door	RS dCi 175 5-door
<b>SAFETY AND SECURITY</b>		
<b>Active and Passive Safety Features</b>	•	•
ABS with EBD (Electronic Brake Distribution)	•	•
Sports-tuned ESP (Electronic Stability Program) with understeer control	•	•
Driver and front passenger adaptive SRS airbags	•	•
Driver and passenger lateral SRS airbags	•	•
Side SRS curtain airbags (front and rear)	•	•
Dual rear lateral SRS airbags	•	•
Programmed Restraint System	•	•
Load force limiters in safety belts and pretensioners	•	•
Three 3-point rear seatbelts with pretensioners on the outer rear seats	•	•
Side impact bars and honey-combed padding in doors	•	•
Door open and fasten seatbelt indicators	•	•
Cruise control with speed limiter	•	•
Auto headlights and wipers	•	•
Xenon headlights, fog lights and 'See me home' function headlights	•	•
Fuel cut-off in event of impact	•	•
<b>Security Features</b>	•	•
Engine immobiliser	•	•
Remote central locking and Renault Anti Intruder Devide (R.A.I.D)	•	•
<b>INTERIOR FEATURES</b>		
Height and reach adjustable steering wheel	•	•
Leather-trimmed steering wheel and gear knob	•	•
Leather-trimmed upholstery	•	•
Climate control air conditioning	•	•
Air recycling and particle filter	•	•
Trip computer and outside temperature gauge	•	•
4x40w AM/FM stereo with 6-CD changer and fingertip remote control	•	•

	RS 225 5-door	RS dCi 175 5-door
Electric power windows with 'one touch' on driver's side	•	•
Electric door mirrors	•	•
Height and lumbar adjustment on driver's seat	•	•
Height and recline adjustable front head restraints	•	•
Front and rear armrests	•	•
60:40 split folding rear seats	•	•
Drilled aluminium pedals	•	•
Air-chilled glovebox	•	•
Front under floor storage	•	•
'Clean Hands' integrated fuel filler cap	•	•
<b>EXTERIOR FEATURES</b>		
Body coloured bumpers	•	•
Satin chrome door handles	•	•
Signature charcoal rear vision mirrors	–	•
Chrome double outlet exhaust	•	•
Signature charcoal 18" alloy wheels	•	•
<b>OPTIONS</b>		
Metallic paint		
<b>WARRANTY</b>		
3 Year/100,000km with 24 Hour Roadside Assistance		

## COLOURS



NNF TORO RED (SOLID) F60 SILVER (METALLIC) GNA DEEP BLACK (METALLIC) RND ALP BLUE (SOLID)

It should be noted that printing limitations do not permit the subtle paintwork shades on these pages to be shown with absolute accuracy. Only personal inspection of the Mégane RS 225 and RS dCi 175 at your Renault Dealer will reveal it in its true colours. From time to time changes are made to the colour range. Please check availability with your Renault Dealer.



## **RENAULT, THE ONLY CAR MANUFACTURER TO HAVE 11 VEHICLES AWARDED 5 STARS IN THE EURO NCAP CRASH TESTS**

Renault's passion for performance, style and safety is what drives us to create unique automotive concepts, ranging from practical and versatile people movers to high performance coupés and hot hatches. But there is one thing that they all share in common, and that is the race-bred technology that makes every Renault a pleasure to drive and own.

Our Formula 1 programme provides a perfect test bed for technological innovation and development, with many of the new materials and technologies developed to produce a winning race car finding their way into our road-going vehicles. Constant improvements in performance, handling and safety can be directly attributed to Renault's passion for racing and the transfer of skills between the Renault Technocentre and our Formula 1 team. Our goal is to create the ultimate Renault driving experience. Drive a Renault today and you'll understand what we're talking about.



## ECOLOGICAL ECONOMICAL



Renault's environmental policy is based on an understanding of the ecological challenges that our planet faces. This policy aims to make Renault one of the world's top three car makers for low level emissions of CO2.

Renault underlines its commitment to protecting the environment and so offers a range of vehicles that are both economical and ecologically sound.

- Ecologically sound through a commitment to reducing the environmental impact for the entire lifespan of the car. From the outset, each new project incorporates production processes, choice of materials, pollutant and CO2 emissions, fuel consumption and recycling.

- Economical in terms of fuel consumption. Renault emphasises that the solution to many great ecological challenges lie in technological advancements that can be applied to the majority of vehicles whilst maintaining attractive pricing.

- Recycling – Renault strives to manufacture vehicles that are environmentally safer than ever before. One of Renault's strengths is its capacity to integrate the environment into every stage of a vehicle project right from the design phase until the end of its life cycle. Eco-design of current Renault vehicles enables 95% of their weight to have a second life. It also means that an increasing number of components are made of recycled plastics and renewable materials.



## FORMULA 1, A SCHOOL OF EXCELLENCE



Formula 1 is an extremely demanding sport. It teaches us that what really counts, besides performance, is the ability to construct reliable cars which won't let you down, despite being subjected to extreme physical conditions.

We have applied this philosophy not only to our racing cars. Because our commitment to Formula 1 has only one aim: to teach us how we can offer you reliable, safe, high-performance cars, upon which you can always rely.



## SERVICE AND MAINTENANCE. HELPING YOU STAY PRODUCTIVE AND COMPETITIVE...

All new Renault Sport vehicles are covered by a 3 Year/100,000 Kilometre Warranty and Renault 24 Hour Roadside Assistance Program.

With over 100 years experience as a motor vehicle manufacturer and as Europe's largest automotive brand the Renault service and maintenance network offers peace of mind for all new Renault owners.

Each of the approved and authorised Renault Dealerships across Australia have completed rigorous training programs in parts, service and maintenance.

They can maintain your new Renault at peak efficiency – in workshops equipped with the very latest technology and specialist tools. All Renault Dealerships can also supply you with parts, accessories, the latest Renault promotional merchandise and friendly, helpful advice.

# RENAULT SPORT CLIO 197, MEGANE dCi 175, MEGANE 225



([www.renault.com.au](http://www.renault.com.au))

**3**  
**YEAR WARRANTY**  
100 000 km  
RENAULT recommends 

For more information call 1800 009 008 or visit [www.renault.com.au](http://www.renault.com.au) In New Zealand call 0800 RENAULT (736 285) or visit [www.renault.co.nz](http://www.renault.co.nz). Disclaimer: Details as at May 2009 and subject to change. Colours shown are indicative only, please see your dealer for full details. Vehicles displayed in this brochure are overseas models and shown for illustration purposes only. Australian vehicles may differ in characteristics, specifications, equipment, accessories and colours than shown in this brochure. Vehicle Distributors Australia Pty Ltd and Motorcorp Holdings Ltd reserve the right to modify its models without notice including their characteristics, specifications, equipment, accessories and colours. Publication date May 2009. Vehicle Distributors Australia Pty Ltd 260-284 Frankston-Dandenong Road, Dandenong South, Victoria 3175

REN1534